

MAKUM Jn. 'C' CLASS/STD-II(R)/EI

KM.-55.62 (FROM DBRT)

UP →

C/L OF 'C' CLASS L-XING GATE(M)
No. 58/DD, AT HP. 57/6-7

EMERGENCY KEY ELECTRICALLY
INTERLOCKED WITH CONCERNED
SIGNALS FOR L.C. GATE No. 55-DD
IN GLASS FRONTED CASE
(SEALED & PAD LOCKED)
(AT GATE GOODTY)

C/L OF 'A' CLASS L-XING (M)
GATE No. 55/DD, AT KM. 55/4-5

- TO 'C' CLASS LC GATE(M) No. DD/84, AT KM. 86/5-6
- TO 'C' CLASS LC GATE(M) No. DD/72, AT KM. 74/5-6
- TO 'C' CLASS LC GATE(M) No. DD/76, AT KM. 77/3-4
- TO 'C' CLASS LC GATE(M) No. DD/82, AT KM. 85/1-2
- TO 'C' CLASS LC GATE(M) No. DD/80, AT KM. 81/3-4
- TO 'C' CLASS LC GATE(M) No. DD/77, AT KM. 78/6-7
- TO 'C' CLASS LC GATE(M) No. DD/75, AT KM. 77/1-2
- TO 'C' CLASS LC GATE(M) No. DD/70, AT KM. 73/1-2
- TO 'C' CLASS LC GATE(M) No. DD/69, AT KM. 72/1-2
- TO 'C' CLASS LC GATE(M) No. DD/68, AT KM. 71/7-8
- TO 'C' CLASS LC GATE(M) No. DD/62, AT KM. 66/8-9
- TO 'C' CLASS LC GATE(M) No. DD/63, AT KM. 68/2-3
- TO 'C' CLASS LC GATE(M) No. DD/73, AT KM. 75/9-76/0
- TO 'C' CLASS LC GATE(M) No. DD/81, AT KM. 81/7-8

C/L OF 'C' CLASS L-XING GATE(M)
No. 53/DD, AT KM. 54/2-3

C/L OF 'C' CLASS L-XING GATE(M)
No. 54/DD, AT KM. 54/8-9

TSK JN.
KM.8.34
← TSK END

TINGRAI
KM.13.32
LEDD END →

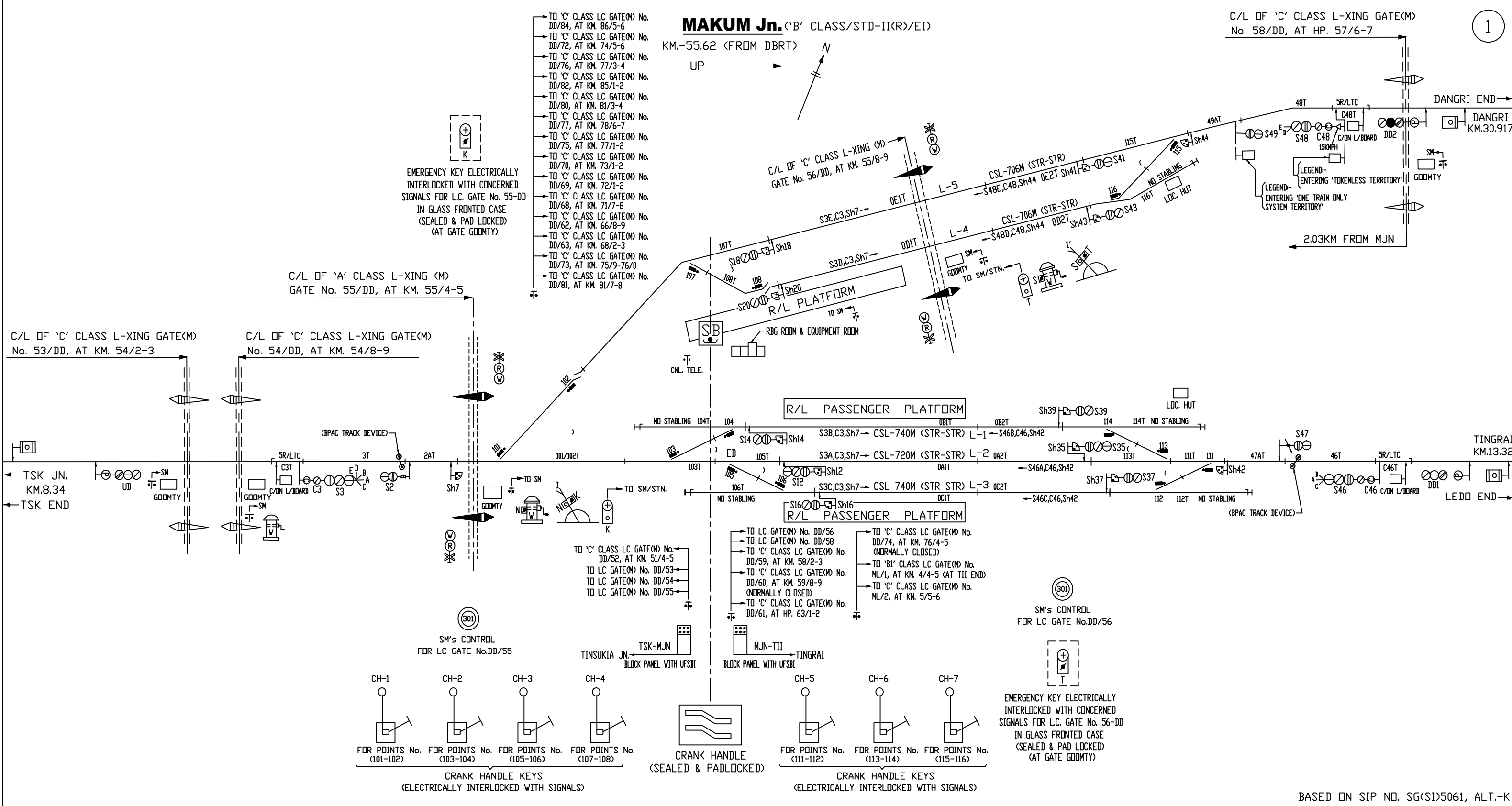

DIGBOI ('B' CLASS/STD.-II(R)/E/D)

KM.-25.22 FROM MJN.

UP →

Z ←

EMERGENCY KEY ELECTRICALLY INTERLOCKED WITH CONCERNED SIGNALS FOR LC GATE NO. 6/ML IN GLASS FRONTED BOX (SEALED & PADLOCKED) (AT GATE GOOMTY)

EMERGENCY KEY ELECTRICALLY INTERLOCKED WITH CONCERNED SIGNALS FOR LC GATE NO. 7/ML IN GLASS FRONTED BOX (SEALED & PADLOCKED) (AT GATE GOOMTY)

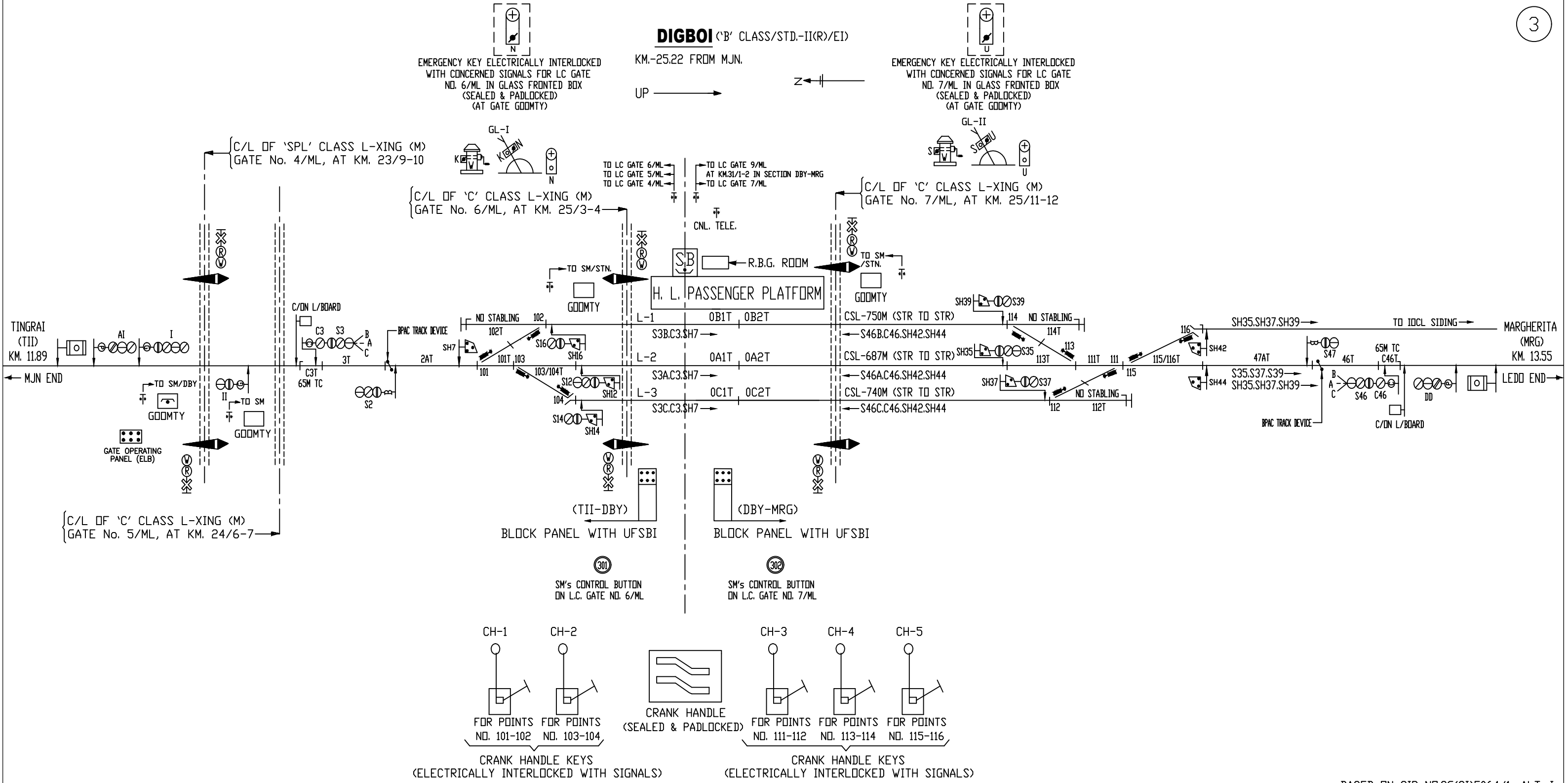

MARGHERITA ('B' CLASS/STD.-II(R)/EI)

KM.-38.76 FROM MJN.

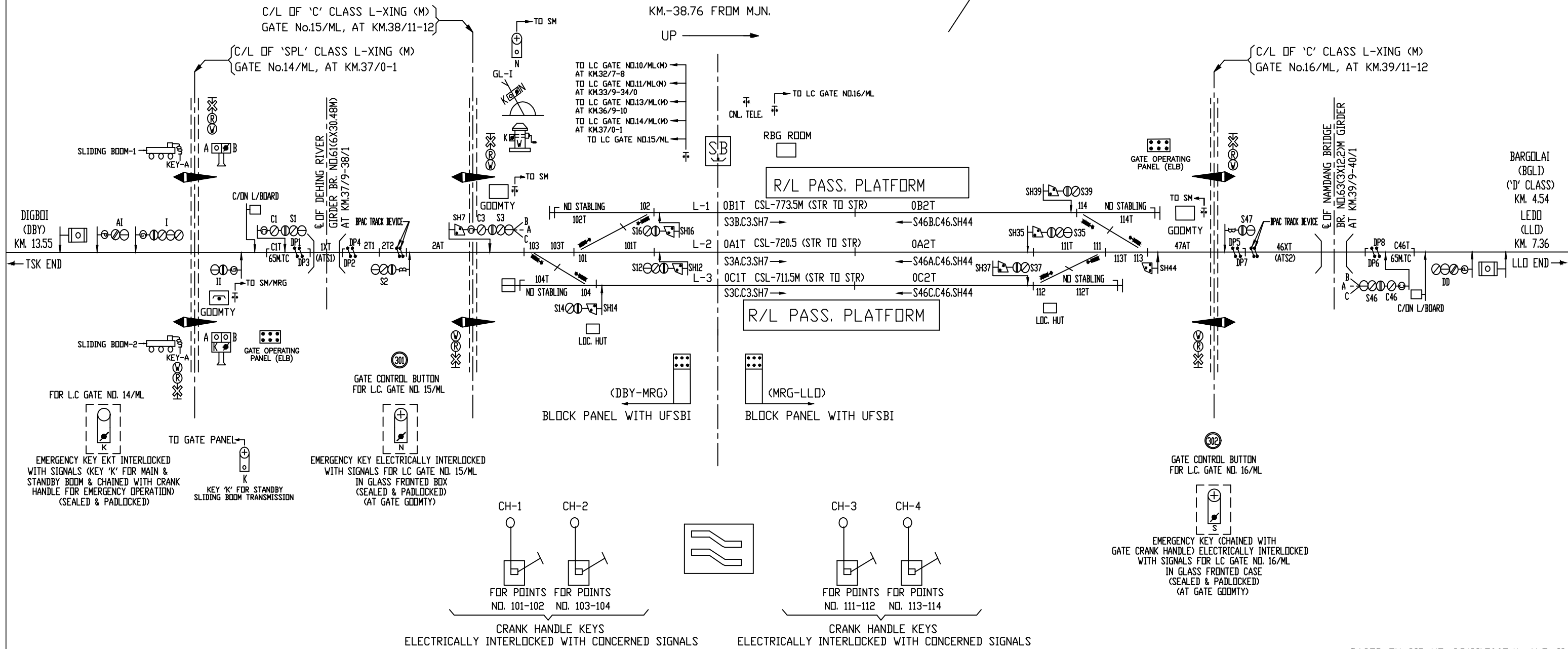
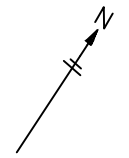

BASED ON SIP NO. SG(SI)5067/1, ALT.-II

BARGOLAI (D' CLASS)

KM.- 43.30



TIRAP SDG. ('DK' CLASS)

KM.- 49.13

